

## Controller Installation Supplement May 2007

The Salamander door holder system now has several new features to meet the latest best practise recommendations from BSI.

- Battery back up for 6 hours of mains failure
- Fault monitored connections to fire panel
- Configurable inputs for 24V signal or "voltage free" relay

Please read these instructions in conjunction with the Salamander User Guide.

### Mounting Door Holders

Door holders are now configured for mounting horizontally to give better access to the release switch and battery cover. A label on the reverse of the unit shows the correct mounting.

### Controller – Mounting and Wiring

See the User Guide for mounting instructions. For best radio reception, do not mount in a corner or recess. There should be at least 600mm clearance from the controller to the ceiling or any wall.

Wiring into the host fire panel. The controller must be connected to the building fire system so that it will be triggered when there is a fire condition or fault condition at the fire panel. This can be either via a nominal 24V dc (5V – 30V) signal that is usually on in normal conditions, or via a normally closed relay contact.

The diagram opposite shows the connections for a 24V dc input from the fire panel. A "normally on" input is required to keep the controller in its operating mode. Once the input voltage is interrupted the controller will release the doors. In this way a break or short in the wiring will trigger the controller. It is possible to reverse the input to a "normally off" signal by selecting command code 05.

The controller is supplied with wire links from the relay terminal to the fire and fault terminals. These should be removed when making the connections to the fire panel. If no fault input is being used, leave the wire link between the relay and fault terminals connected.

Alternatively, the controller can be connected to relay outputs on the fire panel or an auxiliary device as shown in the opposite diagram.

Using a normally closed relay contact is preferred as it will guard against a broken wire (but not against a short circuit in the connection). Select command code 05 to reverse the input to suit a normally open relay contact.

Once all wiring is installed, connect the backup battery pack to the flying leads with matching connector on the main PCB. Stow the battery pack at the top or right hand side of the enclosure. Note that the battery will take 16 hours to fully charge.

The common negative on the controller is linked to safety earth. If an earth fault is indicated on the fire panel once the connections have been made, locate the wire link above the screw terminals on the controller PCB labelled earth link and cut it.

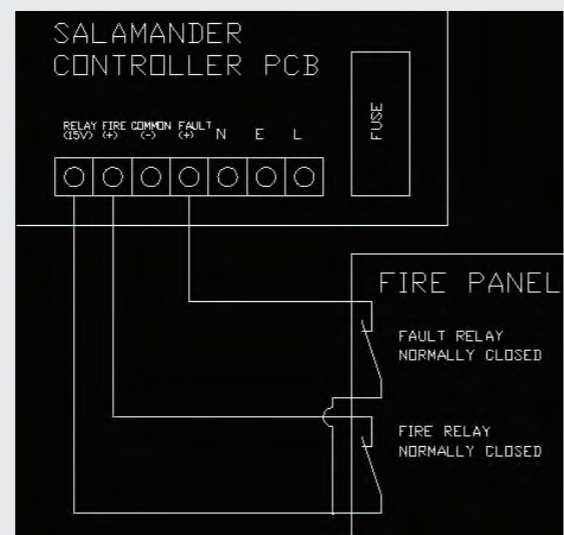
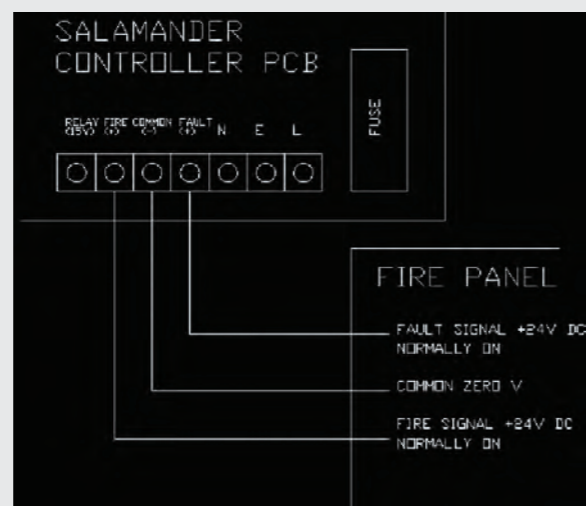

### Living With The System

Refer to the user guide for a description of the messages displayed by the controller. Low Battery, Low Signal and No Signal warnings from each door holder in the installation are automatically collected and shown on the controller.

If there is a mains power failure, the controller backup battery will continue to power the controller for at least 6 hours. When the controller is running on battery power, the display LEDs switch off to conserve power and after 1 minute the number display switches off too. The only indication that the controller is still working is a green dot in the number display flashed every 8 seconds. All keypad functions and the fire panel inputs still remain active. Once the backup battery is exhausted, all door holders will be released.

When mains power is restored, the controller will switch back into normal operation and recharge the backup battery if required. Note that if the doors have been released for some time each door holder will have gone to sleep. Press the red button on the door holder to wake it.

Backup batteries in the controller (and boosters) should be replaced every three years or sooner to maintain performance.

### Command Codes

Refer to the user guide for how to enter command codes. The codes are now as follows:

00	Set key-lock code
01	lock keypad now
02	1 second broadcast
03	4 second broadcast
04	standard broadcast interval
05	toggle fire and fault inputs – see over page
06	door holder statistics
07	development use only
08	poll door holder 1
09	development use only
10	software version no.
11	un-enrol booster
12	poll specified door holder for 10 minutes

### Boosters

Boosters are now supplied in the same size case as the controller and include a backup battery to give 6 hours running during mains failure. They should be wired into a permanent mains connection. Refer to the fitting instructions supplied with the booster.

For site surveys, a special battery powered Survey Tool is now available. Contact your distributor for details.

# DOOR HOLDER USERGUIDE



## CONTENTS

Introduction & System Overview.....	1
General Operation.....	1
Specification.....	2
Mounting & Wiring.....	2 - 3
Programming Controller.....	3 - 4
Mounting Door Holders.....	4 - 5
Testing.....	5
Living with the system.....	5-6
Removing Door Holders.....	6
Door Holder Installer Supplement.....	7 - 8

**Introduction and System Overview**

The Salamander Wire-Free Door Holder is battery powered and radio controlled - combining ease of installation and comprehensive safety features to award the user with uninhibited access through buildings. A basic system consists of one control panel with up to 99 door holders under its supervision.

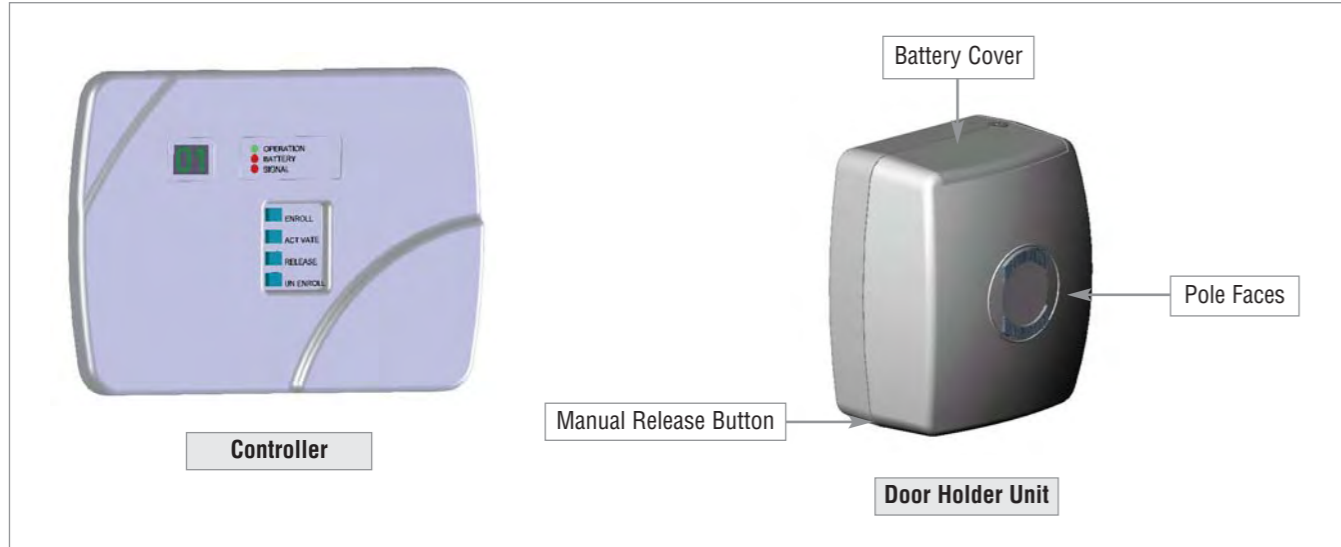

All door holders have a unique ID, which is logged to the control panel's memory during enrolment. The control panel is connected to the host fire system to detect a fire alarm. The controller continually talks to each door holder to say that its OK to hold open the door. When an alarm is triggered, this message stops and the doors release to a safe position. The controller regularly interrogates all units to ensure correct operation. If a door holder loses radio contact or senses that its batteries are critically low, it will 'fail safe' and release the door.

Please note that the controller should only be installed by a technically competent person to comply with EN1155. The door holders must not be used to retain doors at an angle of less than 65°. Radio boosters may be required to give full coverage of your installation. A site survey can be conducted before installing.

**General Operation**

**How to hold the door open?**  
Push the door so the keeper plate makes good contact with the pole faces.

**How to release the door?**  
Press the Manual Release Button.

**How to manually release all doors?**  
Press Release Button on Controller. All doors will release after approx 15 seconds.

The 7 segment display shows E indicating that the instruction has been successful

**Note:** System resets 30 seconds after a release of all doors

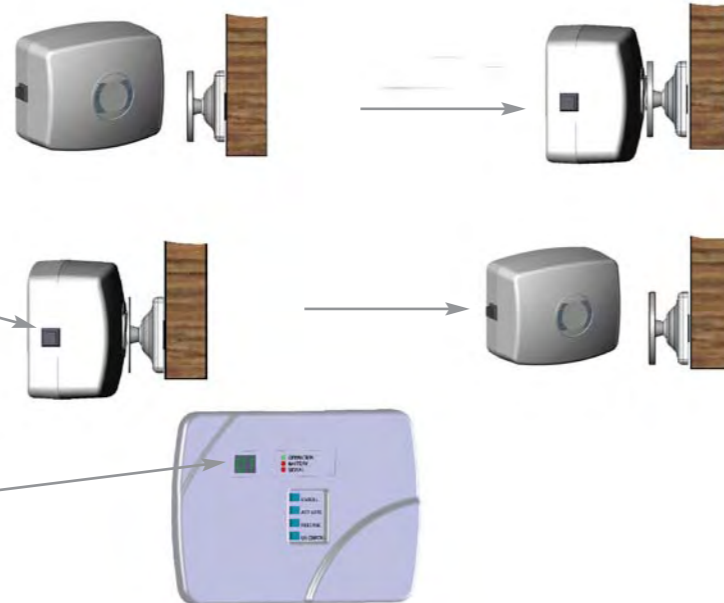

**Specification**

Electrical Data	Controller	Door Holder
Power Supply:	230Vac 50Hz	3.35 V
Current Consumption:	0.02A	0.2A max
RF Data		
Operating Frequency:	868.9MHz	
Transceiver Range:	20 - 50m depending on the building	
Receiver Type:	2 stage superheterodyne receiver architecture	

CE	Stephenson Gobin Ltd Bishop Auckland DL14 0HY England	06				
	T.B.A	EN1155:1997 + A1:20002	5	5	5	1 1 0

We reserve the right to amend data and specifications without notice

**Controller - Mounting and Wiring**

Mounting the Controller: The controller will need to be located beside the host fire alarm panel (or alternatively, near a 24V alarm signal device, e.g. sounder or beacon, with convenient mains power). If possible, choose a location in the center of the area where the door holders will be fitted. **Mount at head height or above for best radio reception.**

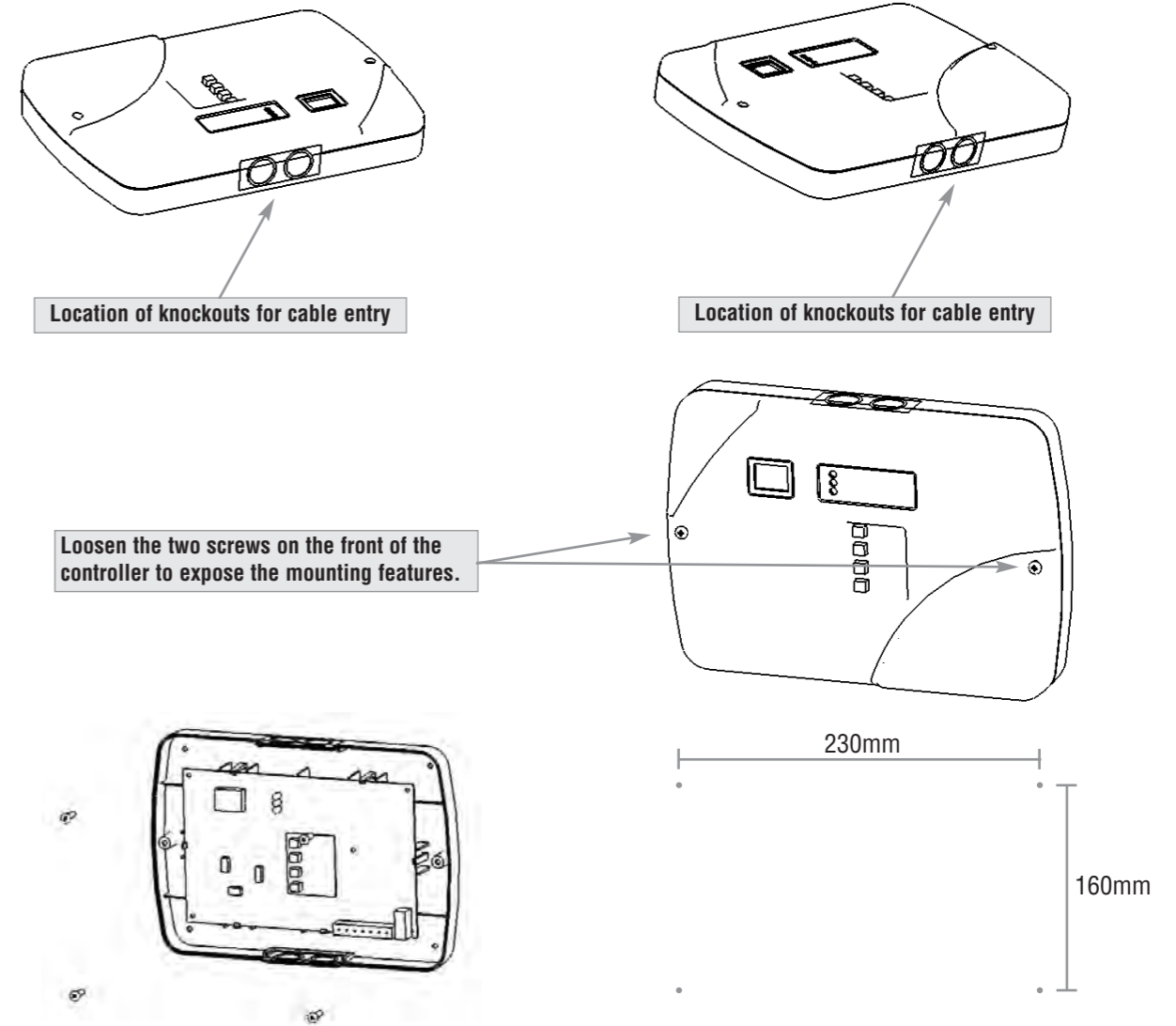

Use 4 screws and follow the dimension layout given above. Securely fix the controller to the wall but take care not to distort the case back.

**Controller Mounting and Wiring**

**Mains Power Supply :** A three core wire that meets relevant wiring regulations should be used to supply mains power to the controller. It should be no greater than 2.5mm<sup>2</sup> and be brought in using one of the knockouts provided in removable inserts in the top and bottom edge of the controller.

**Wiring the controller into host fire alarm or trigger circuit:** The Controller must be wired into the host fire system to give a 24V signal when there is a fire alarm (e.g direct from the fire panel or a sounder circuit). There are 2 pairs of input connection provided, one for a 'fire' signal and one for a 'fault' signal if required.

Either input triggers the unit to release mode on receipt of a 24V signal.

**Once this is done secure the front cover to the back using the two screws before switching on the mains supply.**

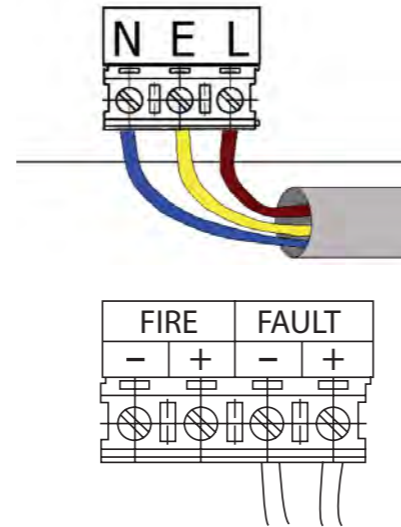

**Enroll Door Holders**

Each door holder has to be "introduced" to the controller so that they recognise each other. We call this enrolling. We recommend that the door holders be enrolled at the controller prior to fitting them to doors.

Only one un-enrolled unit can be enrolled at a time. Ensure all other un-enrolled units have no batteries fitted. Insert the batteries while holding down the red manual release button.

You will hear the door holder running a test cycle for around 10 seconds.

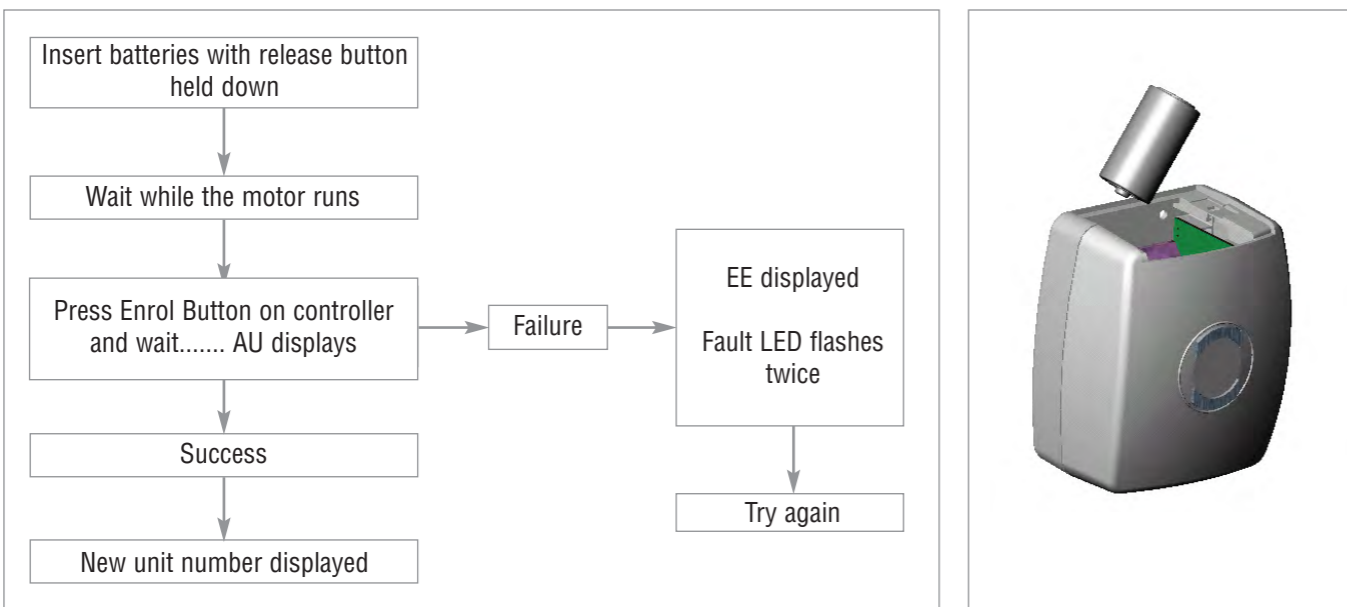

Note the number displayed and record it on the back of the door holder. Once it is fitted behind its door, write a list of which number door holder is located where in the building. Then if the controller ever indicates a fault with one unit it can easily be traced. Fit the battery cover and check the door holder becomes magnetic.

**Note:** It takes up to 1 minute for the door holder to become magnetic after enrolling. The door holder will not energise its magnet until the battery cover screw is fully inserted.

**Mounting Door Holder**

Remove the battery cover and batteries.

Fit the door holder to the wall behind the fire door, at least 500 mm from the axis of the hinge. To avoid warping the door and to give best radio reception, we recommend fitting at a height close to that of the door closer but within easy reach of the release button when the door is open – typically at head height. To give best radio reception, mount with the longer side vertically as shown below. Drill three mounting holes using the drill template supplied (and insert masonry plugs if required). Screw the mounting lug on the fixing surface as shown below. Fit the door holder to it and slide up to lock in place. Fit the remaining two screws through the battery compartment.

Fit the rubber sleeve into the back of the keeper. Fix to the back of the door to line up with the steel poleface of the door holder. The keeper will adjust through 30 degrees to help alignment.

For positions where the door is not close to a wall, a keeper plate with 1 M of chain is available. A floor-mounting bracket is also available if no other solution is possible.

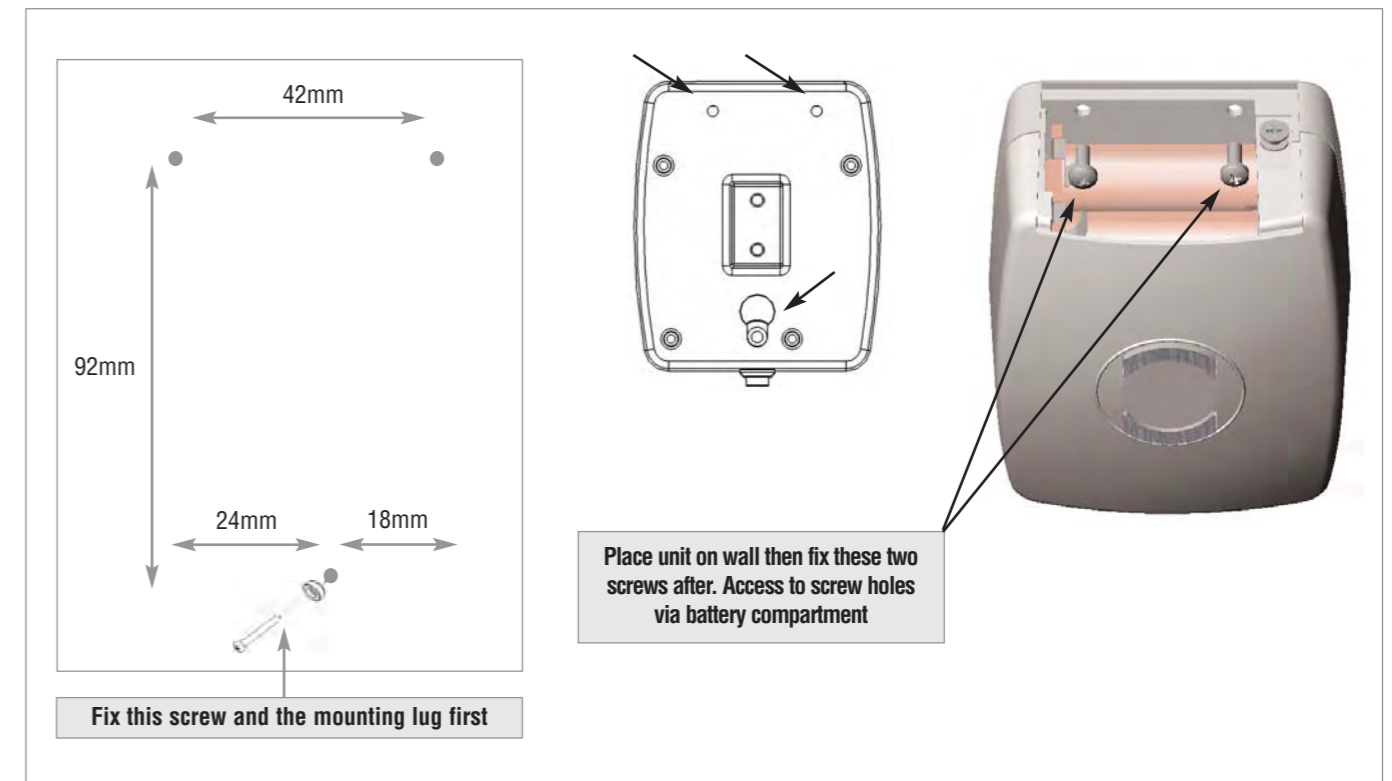

**Mounting Door Holder**

Refit the batteries, fit the cover back in place and tighten the screw.

**Do not hold down the red button while inserting the batteries unless you want to enrol it to a different controller!**

**The magnet will not turn on until the battery cover screw is fully inserted.**

Once it is activated, the door holder may take up to 30 seconds to synchronise with the controller before it turns on its magnet. Open the door so that the keeper plate touches the poleface of the door holder and check that the door holds open.

Press the red button. After 3 seconds the magnet will switch off and door will release.

After a further 10 seconds the magnet turns on and the door can be held open again.

If the battery cover screw is loosened at any time, the magnet will switch off and remain off until the cover is refitted.

If your door holder will not turn on once fitted you may require a booster to improve the radio signal. Contact the Help desk for advice.

**Testing**

Ensure all doors are cordoned off to avoid injuring people passing through while testing the system. With the controller powered up, all the door holders will switch on their holding mechanism after 30 seconds. Press the release button, the LEDs will flash to show a release has been requested. Within 30 seconds the display will show "E" and all door holders will release. Each door holder will switch back into holding mode 30 seconds after the release.

Repeat this test with a simulated alarm from the fire panel. The display will show "AL" and all doors will release within 30 seconds. Note that a signal must be seen from the fire panel for at least 2 seconds to trigger an alarm.

To clear the alarm, wait at least 1 minute. Press the activate button. The display shows OP and the system is ready to hold doors again.

If the doors are released for more than 5 minutes – due to testing or failure of the mains power for example – each door holder will go into sleep mode to conserve battery power. Press the red button on the door holder to wake it up.

Check for any faults indicated at control panel, see living with the system.

Note that it takes 3 minutes for a door holder to fully synchronise with the controller and during this time it will not transmit a status message.

**Living with the system**

Test your door holders every week as part your regular fire system checks. Simulate a fire alarm and check that every door releases (see testing).

The system will check the status of each door holder automatically every 2 hours. If a fault is found the number display will show the door holder number and a red LED will light to show the fault. If more than one door holder has a fault, the display will list them in turn. Press the activate button at any time to start a fresh system check. See diagram on next page.

Replace door holder batteries when indicated at the control panel, using 2 x C cells (LR14). Use only good quality alkaline batteries. If the batteries are not replaced the door holder will eventually release and will not hold reliably until fresh batteries are fitted. Battery life will depend on how frequently the door holder is released and on the quality of the radio signal it receives.

Frequent low signal faults show that a booster is required to give an acceptable radio signal to the door holder indicated.

A "no signal" fault indicates that the door holder has failed to respond to the controller. If the door holder still works and the fault clears by itself within minutes, this is temporary loss of a status message and no cause for concern. If the door holder is released then either it is out of radio range or the batteries are flat/removed.

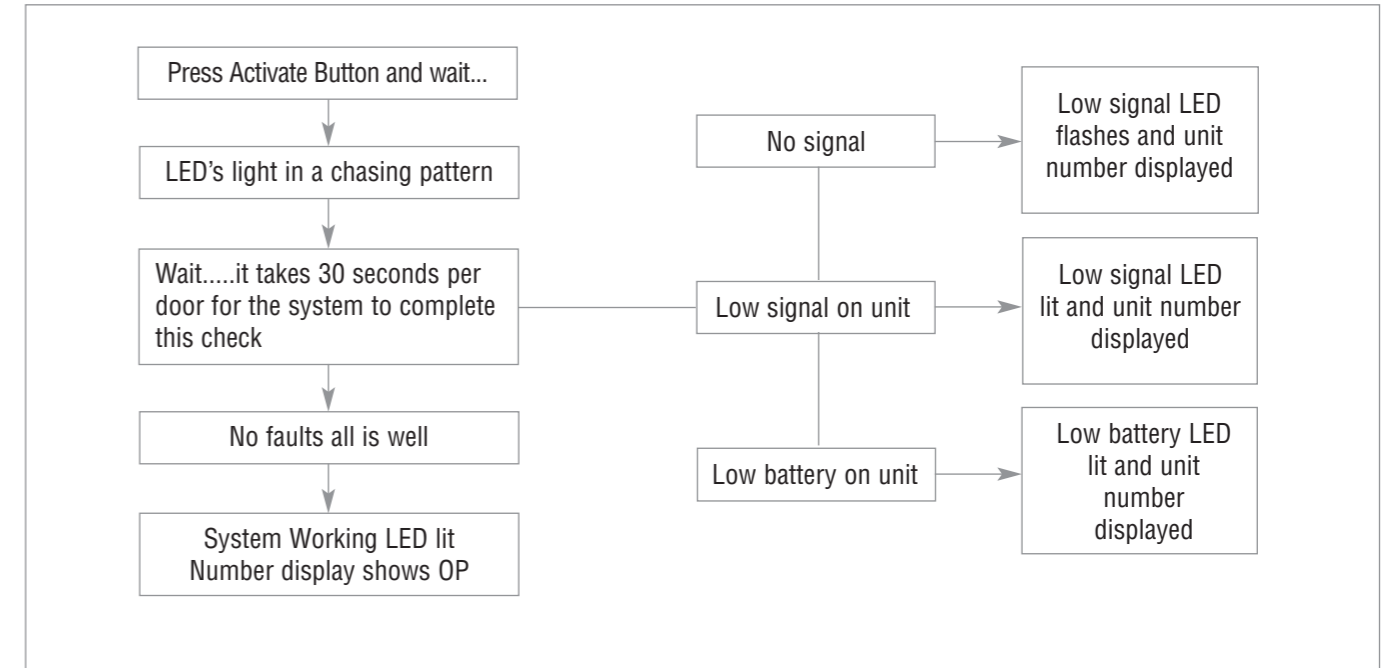

**Removing Door Holders**

If you permanently remove a door holder from the system, use un-enroll to prevent the controller displaying error messages. Remove the unit from it's current location and press the **UN-ENROL** button on the controller.

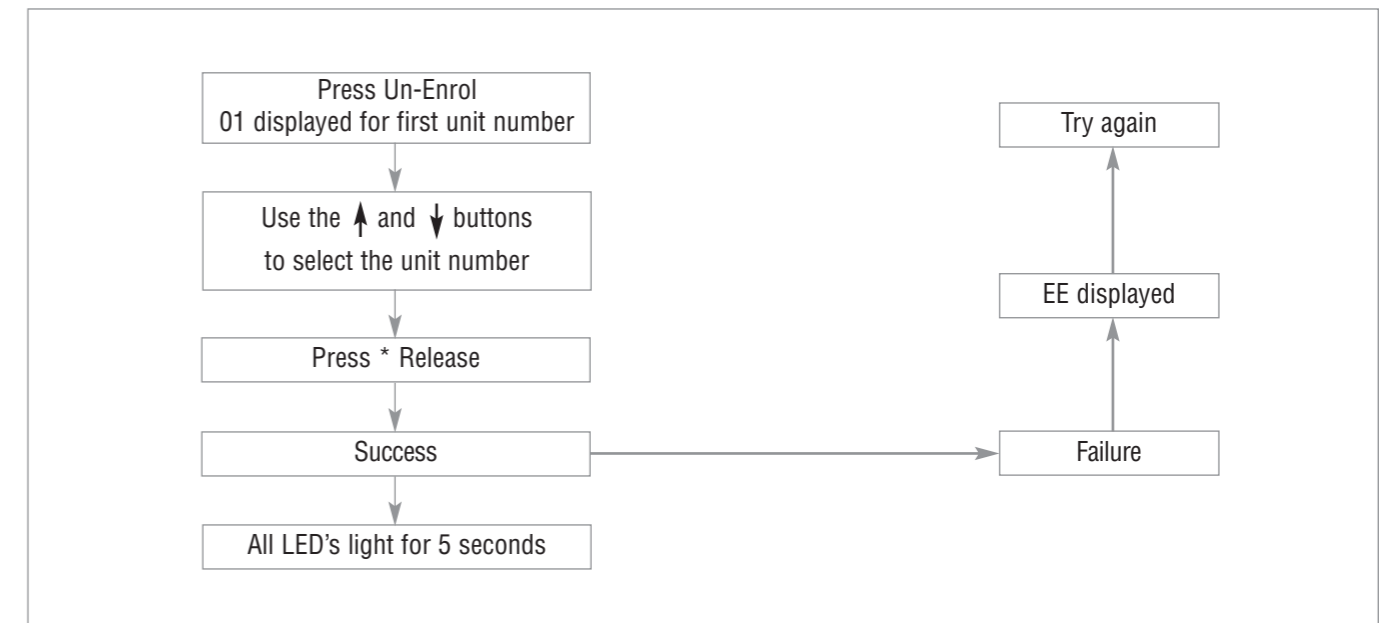

After un-enrolling a door holder from the system, its number "slot" becomes spare and is filled the next time a unit is enrolled. E.G. Un-enrol number 5. The next door holder to be enrolled becomes number 5.

Note that the door holder will continue to respond to the controller until it is enrolled to another installation.

**Trouble Shooting Help Desk:** Tel: 01388 830909 or E-mail: salamander@geofire.co.uk

### Command Codes

There are a number of extra functions built into the controller to assist with installation and troubleshooting. In some cases, these should only be used under instruction from the manufacturer.

To select one of these codes, first put the controller into COMMAND MODE.

1. Press and hold the bottom two buttons – un-enrol and \*release – then release them. The display will show 00.
2. Use the up and down arrow keys to select the code number on the display.
3. Press and release the \*release button to select the code.

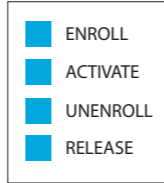

- |   |   |
|---|---|
| 00. Set key-lock code, see below  | 05. Un-enrol all door holders and repeaters. Consult manufacturer before using this option. |
| 01. Lock keypad now.  | 06. Display door holder statistics, see below.  |
| 02. Set controller to 1 second broadcast. Use for site surveys only.                      | 07. Display test.   |
| 03. Set controller to 4 second broadcasts. Consult manufacturer before using this option. |   |
| 04. Return controller to standard broadcast interval.                                     |   |

### Door Holder Statistics

Enter command code '06' Use the up and down arrows to select the door holder number, then press \*release to display each parameter value in the following sequence:-

- a. Controller to door holder signal strength in hexadecimal (63 max)
- b. Door holder to controller signal strength in hexadecimal (63 max)
- c. Battery level in hexadecimal (20=2.7 V ..... 27=3.3 V)
- d. Zone (the node that the door holder is synchronised with: 0=controller, 1-8=repeater number)
- e. The top 2 digits of the door holder ID number in hexadecimal
- f. The middle 2 digits of the door holder ID number in hexadecimal
- g. The last 2 digits of the door holder ID number in hexadecimal

Then select another door holder number or press un-enrol to finish.

### Locking the keypad

If you wish to prevent unauthorised use of the controller, a keypad locking code can be entered. Before the keys are made active a security code must be entered. The code can be any sequence of numbers up to 8 digits long but 2 to 4 digits is usually sufficient.

1. Enter command code '00'
2. 'cd' is displayed then '00'
3. Use the up and down arrow keys to select the first digit of the code on the display. Press the unenrol button to set that digit and move on to the next.
4. When the desired code has been entered press the \*release button.
5. The keypad is now locked. When any key is pressed the display will show 'cd' to prompt the user to enter the code.

To release the keypad, enter the code using the up and down arrow keys and the unenrol key as before to set each digit. When complete, press the \*release button. The keypad will now be fully active and the display will show OP.

The keypad will automatically lock again after 5 minutes of inactivity.

To disable the keypad locking function, prepare to set a new lock code using steps 1 and 2 above. Enter a code of zero by pressing the \*release button again. The keypad will now remain active until a new code is set.

### Site Survey

1. Site the controller temporarily at the desired position. This should ideally be central in the building and at head height.
2. Enrol the booster (if it has not already been enrolled). To do this, insert the batteries in the booster and check the red power LED on the booster lights. Press enrol on the controller – number 1 is displayed to show that this is booster number1.
3. Set the controller to a 4 second broadcast. To do this, enter COMMAND MODE and select option 2 (see page 7).
4. After a synchronisation delay of around 1 minute the green LED on the booster will blink at every broadcast. Site the booster at the required door holder positions moving gradually further from the controller and check the LED blinks consistently.
5. If the signal fails or is not consistent, a booster will be needed between this door and the controller.
6. Identify suitable sites for boosters where the signal is consistently received and where there is convenient mains power. Site a booster here temporarily and continue the survey.
7. Repeat this process as required to cover the required area of installation. Up to 8 boosters can be used in one installation.

### Installing Boosters

Enrol each booster at the controller before fitting in position. Power on the booster (the red LED will light), press enrol on the controller and the booster unit number will be displayed. Record the number on the back of the booster. A display of EE indicates that the enrol has not been successful. Once a booster has been enrolled the green LED will flash with every received broadcast.

Boosters are housed in enclosures similar to the Salamander door holder. Boosters should be wall mounted, above head height and near to a mains supply. Fit to the wall with three screws in the same way.

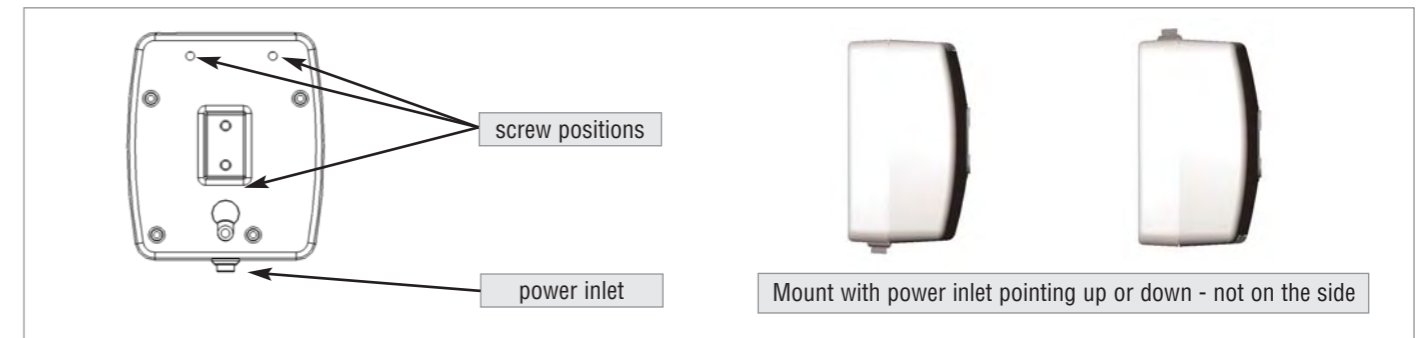

Boosters are supplied with a plug-top power adapter as standard. They may be powered by batteries but only as a temporary measure. A booster with internal power supply suitable for hard wiring into a fused spur is available on request.

Multiple boosters can be used in succession to extend the range in any one direction. In this case, the boosters closer to the controller must have a lower unit number than those further away. See diagram below.

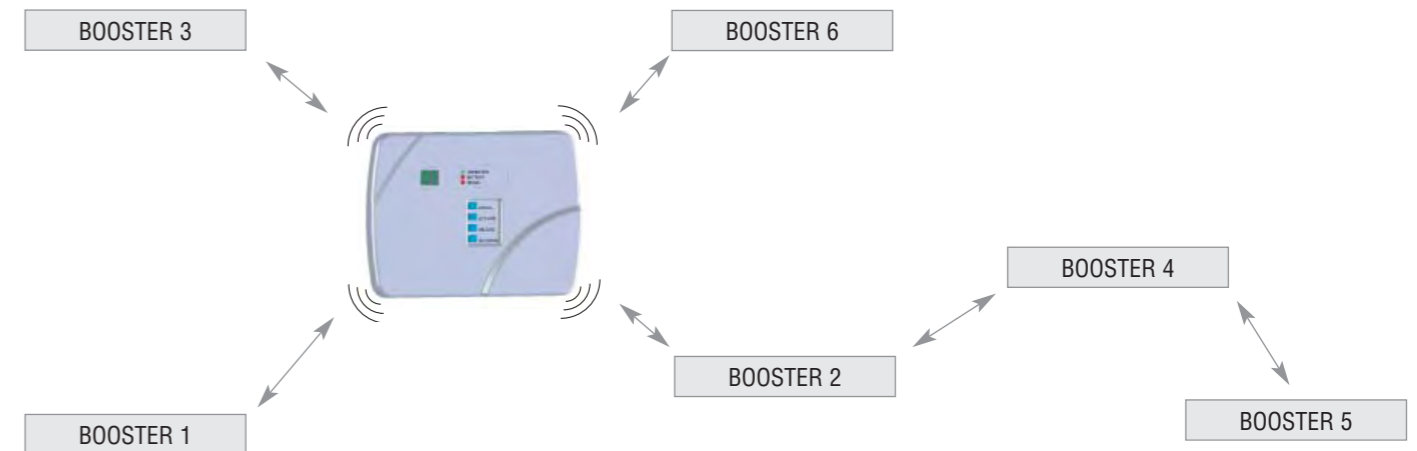

To commission a system of boosters, simply switch them on in order starting with the boosters closest to the controller. When turned on, each booster will lock-on to the strongest signal that it receives whether from the controller or another booster (with a lower unit number). In the same way every door holder when switched on will lock-on to the strongest signal it receives whether from the controller or a booster.

NOTES

NOTES