

- FLOOR, WALL AND CEILING MOUNTING
- 500N OR 1000N HOLDING FORCE
- ZERO RESIDUAL FORCE
- SUPPLIED WITH KEEPER PLATE
- APPROVED IP51 PROTECTION



This rugged, versatile design of door magnet can be used for many different door holding applications. With the magnet set as shown in the photograph, the door holder can be floor mounted or ceiling mounted. Turn the magnet through 90° and the door holder is in wall mounting configuration.

The stand and adjustable head are fabricated from steel providing a very robust structure. A moulded cover is included to conceal the mounting fixings once the holder is fitted.

The stand is available in two standard lengths, but can easily be cut down to shorter lengths on site. Special lengths and voltages are available to order.

### TECHNICAL INFORMATION

Part No.	3-79-05200	3-79-05300	3-79-06200	3-79-06300
<b>Holding Force</b>	500	500	1000	1000
<b>Residual</b>	zero	zero	zero	zero
<b>H1</b>	183	283	183	283
<b>H2</b>	250	350	250	350
<b>Supply</b>	24Vdc	24Vdc	24Vdc	24Vdc
<b>Current</b>	43mA	43mA	76mA	76mA
<b>Keeper Adjustment</b>	+/- 30°	+/- 30°	+/- 30°	+/- 30°
<b>Finish</b>	Nickel Coated / Painted White			

#### Floor/Ceiling Mounting

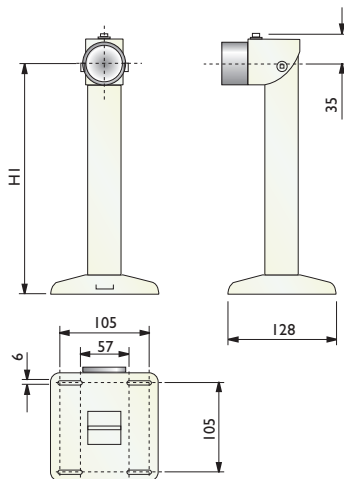

#### Wall Mounting

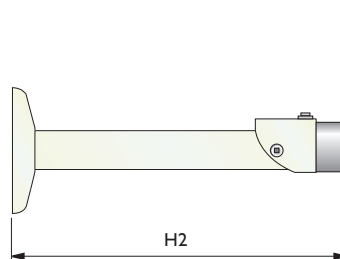

#### Keeper Plate

